

**ECOMIDI**

We are cleaning the world

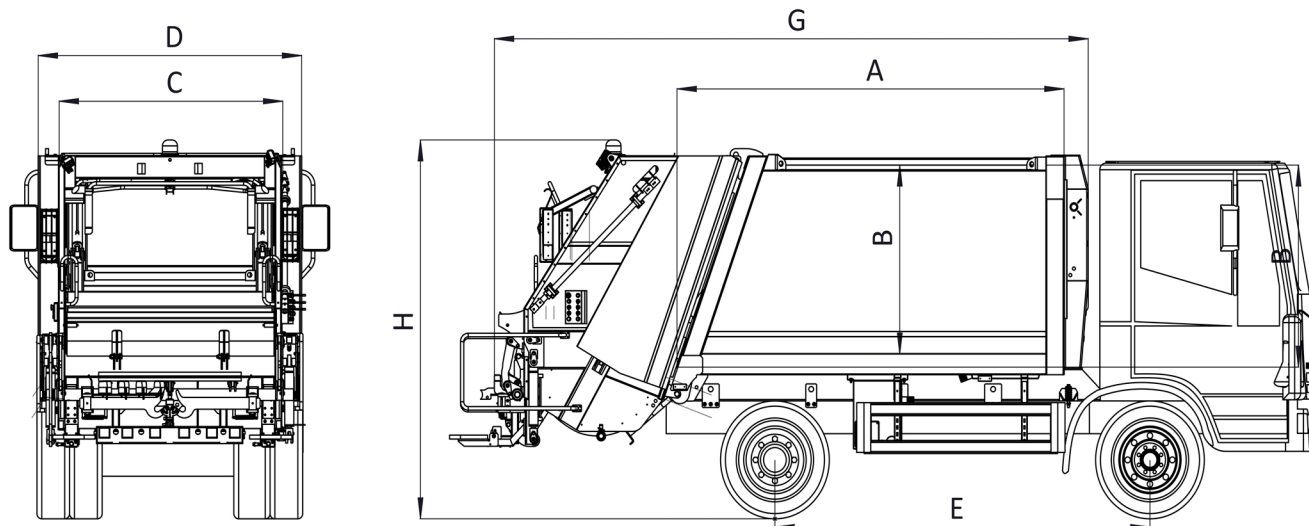

**ECOARBA**  
MACHINERY INDUSTRY



	A	B	C	D	E	G	H
ECOMIDI 5 m <sup>3</sup>	3000	1550	1800	1990	2800-3000	4780	2850-2950
ECOMIDI 6 m <sup>3</sup>	3200	1550	1800	1990	3000-3400	4980	2850-2950
ECOMIDI 7 m <sup>3</sup>	3200	1550	2000	2190	3000-3400	4980	2850-2950
ECOMIDI 8 m <sup>3</sup>	3600	1550	2000	2190	3600-3900	5380	2850-2950
ECOMIDI 9 m <sup>3</sup>	3800	1500	2000	2190	3600-3900	5580	2850-2950
ECOMIDI 9 m <sup>3</sup>	3800	1500	2200	2390	3600-3900	5580	2850-2950
ECOMIDI 10 m <sup>3</sup>	3800	1500	2250	2440	3600-3900	5580	2850-2950
ECOMIDI 11 m <sup>3</sup>	4000	1500	2250	2440	3600-3900	5780	2850-2950
ECOMIDI 12 m <sup>3</sup>	4400	1500	2250	2440	4000-4600	5980	2850-2950

A- Body Length B- Body inside height C-Body inside width D-Body outside width E-Wheelbase G-Body outside length H- Body Height

	BODY	TAILGATE	COMPACTION	EJECTION			
Bottom	4 mm ST32	Hopper	6 mm ST32	Slide	4 mm ST32	Front	3 mm ST32
Sides	3 mm ST32	Sides	3 mm ST32	Compaction	5 mm ST32	Sides	4 mm ST32
Top	3 mm ST32						

Ecomidi is smart model of rear loaded garbage compactor which is suitable for 7-15 ton trucks. It is produced according to EN 1501 standart.

All operational, safety and mechanical properties of Ecomidi is controlled and tested after finishing procedures.

Electrical system is produced according to EN 1501 standart.

Hydraulic system can be produced for single or double control system. Operational pressures are set to a calculated value and it is performed for maximum garbage collection.

Different types of bin lift systems are produced depending on customer demands.

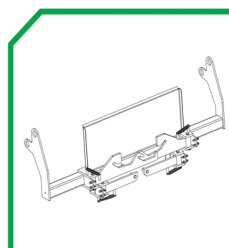

400-800 lt Containers

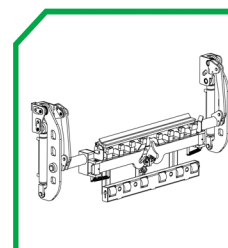

Vertical Heavy System  
120-240-360-770-1100 lt

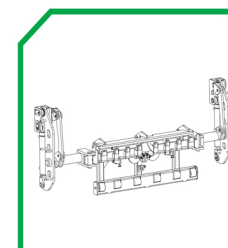

Vertical Light System for  
120-240-360-770-1100 lt

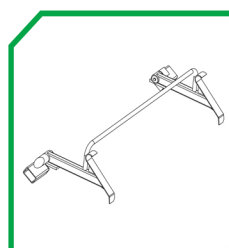

Mechanic Lift Catcher

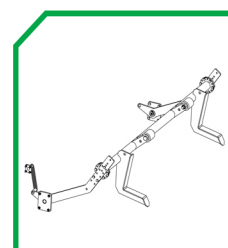

Pneumatic Lift Catcher

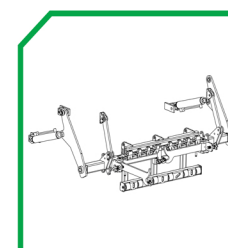

Horizontal System for  
120-240-360-770-1100 lt

<b>Definition</b>	ECOJERA Industry brand Rear loading hydraulic garbage compactor.
<b>General</b>	Body upfit consists of a body mounted on a chassis, a tailgate with compaction mechanism, discharging/ejection plate inside the body, container lifting device, hydraulic and electrical components and their installation on Garbage compactor.
<b>Body</b>	<b>Body Floor :</b> St-52 (S355J2) / 4.0 mm or Hardox 450 <b>Body Sides :</b> St-52 (S355J2) / 3.0 mm - Round body side Without any U-profiles and traverses on body side or Hardox 450 <b>Body Roof:</b> St-52 (S355J2) / 3.0 mm
<b>Dirty Water Tank</b>	There is dirty water tank in front bottom of the body; Volume of dirty water tank is around 60-120 liter
<b>Tailgate (Hopper)</b>	<b>Steel Thickness (mm) :</b> -Tailgate floor, Tailgate Extension inside to body St-52 (S355J2) / 6mm or hardox Material -Tailgate side bottom walls St-52 (S355J2) / 4.0 mm or hardox material -Other areas do not get into contact with garbage friction is from St-52 (S355JR) steel. <b>Hopper Capacity (m3):</b> Water level of tailgate is 1-1,5 m3 <b>Safety Props (bar) :</b> The tailgate is provided with safety props (manual) between the body and tailgate for safety purposes during maintenance or cleaning
<b>Discharge Plate</b>	By means of ejector panel (discharging panel) activated with an hydraulic telescopic cylinder, ejecting plate surface (where contact with the Garbage) made of 3mm St-52. Easy maintenance. Whole side of discharge plate is sealed with plastic.
<b>Compaction Plate</b>	Compaction plate material is 4-5 mm ST52 / Hardox 450 Two compaction cylinder is at the top of the body.
<b>Bin Lift Systems</b>	Suitable for different types of containers. Specialized lifter mechanism Light, heavy, fast and user friendly lifting devices. Automized and manual controls.
<b>Operation &amp; Control</b>	<b>Control :</b> All devices for loading control are mounted on tailgate right side, operation and control is according to EN 1501-1 + A2 standards. Container lifting mechanism control is only by manual control (handles).  Equipped with emergency stop button on both sides of tailgate which stops the movement and plus rescue button which stops and reverse the movement to the beginning position + 1 unit emergency stop button on body left side.
<b>Hydraulic System</b>	<b>Oil Tank :</b> Around 90-180 lt. capacities, equipped with return filter, tank lid, and oil indicator. <b>P.T.O. :</b> Controlled inside the cab, original P.T.O. of the Truck. <b>Working Pressure (bar):</b> Average 180±10 bar. <b>Hydraulic Cylinder :</b> 10 units of hydraulic cylinders and Telescopic Cylinder with 3 extensions. All the Hydraulic Cylinders are double-acting cylinders. The dimensions of cylinders are designed to accomplish the stipulated cycle times and compaction ratio. Pursuant to DIN 2391 C Norms. <b>Compaction Ratio :</b> The compaction ratio (volumetric) varies between 3:1 to 6:1 according to the characteristic of the garbage used in the area. <b>Sealing:</b> With special design leak-proof rubber seal between tailgate and the body.
<b>Electrical System</b>	Produced according to TS EN 1501 standart IP65 water proofed PLC or CanBus system (Option) User friendly



# ECOARBA

MACHINERY INDUSTRY

Rear Loading Hydraulic  
Garbage Compactors

Mini Waste  
Collection Vehicles

Lifting  
Systems

Waste Transfer  
Systems

Garbage Bins  
Cleaning Systems



Ortakonak Mah, Aksaray Cadesi. D:NO 363, 42060 Karatay / Konya / Turkey



+90 532 234 34 40



info@arbaindustry.com



www.arbaindustry.com